

THIS DRAWING IS UNPUBLISHED. RELEASED FOR PUBLICATION
 © COPYRIGHT BY TYCO ELECTRONICS CORPORATION. ALL RIGHTS RESERVED.

Loc	DIST	REVISIONS			
P	LTR	DESCRIPTION	DATE	DWN	APVD
AJ	16	0	REV PER EC-0S14-0496-04	03FEB2005	AF JL

1. CRIMP TOOL: 69141-1
2. RG-59/U,59A/U,59B/U,62/U,62A/U,62B/U,124/U,140/U AND 210/U
3. SEE I.S. 1799-1

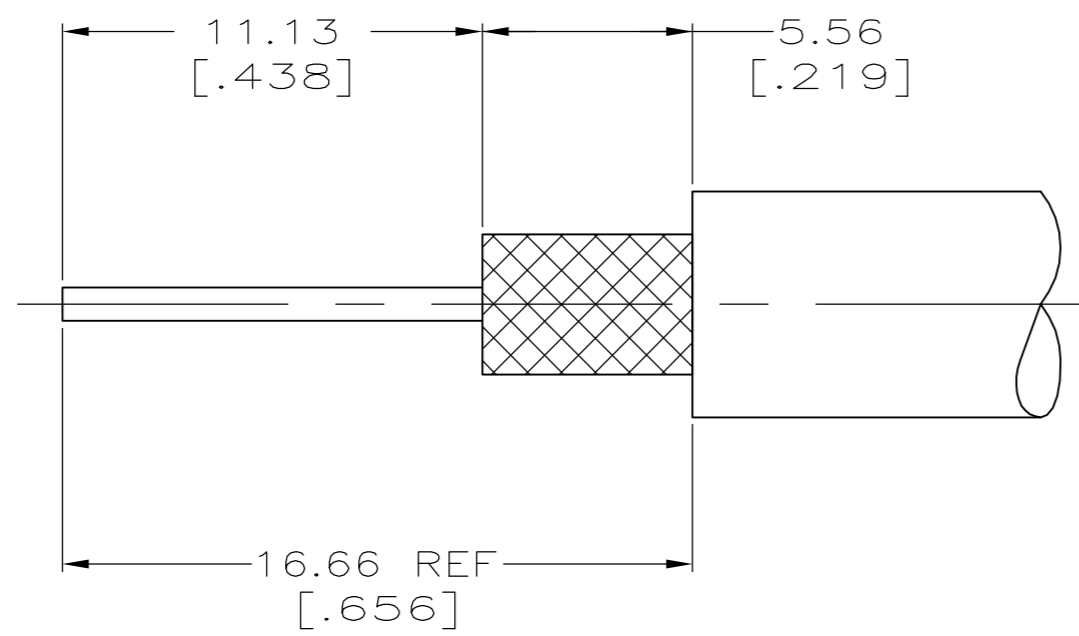

RECOMMENDED STRIP LENGTH

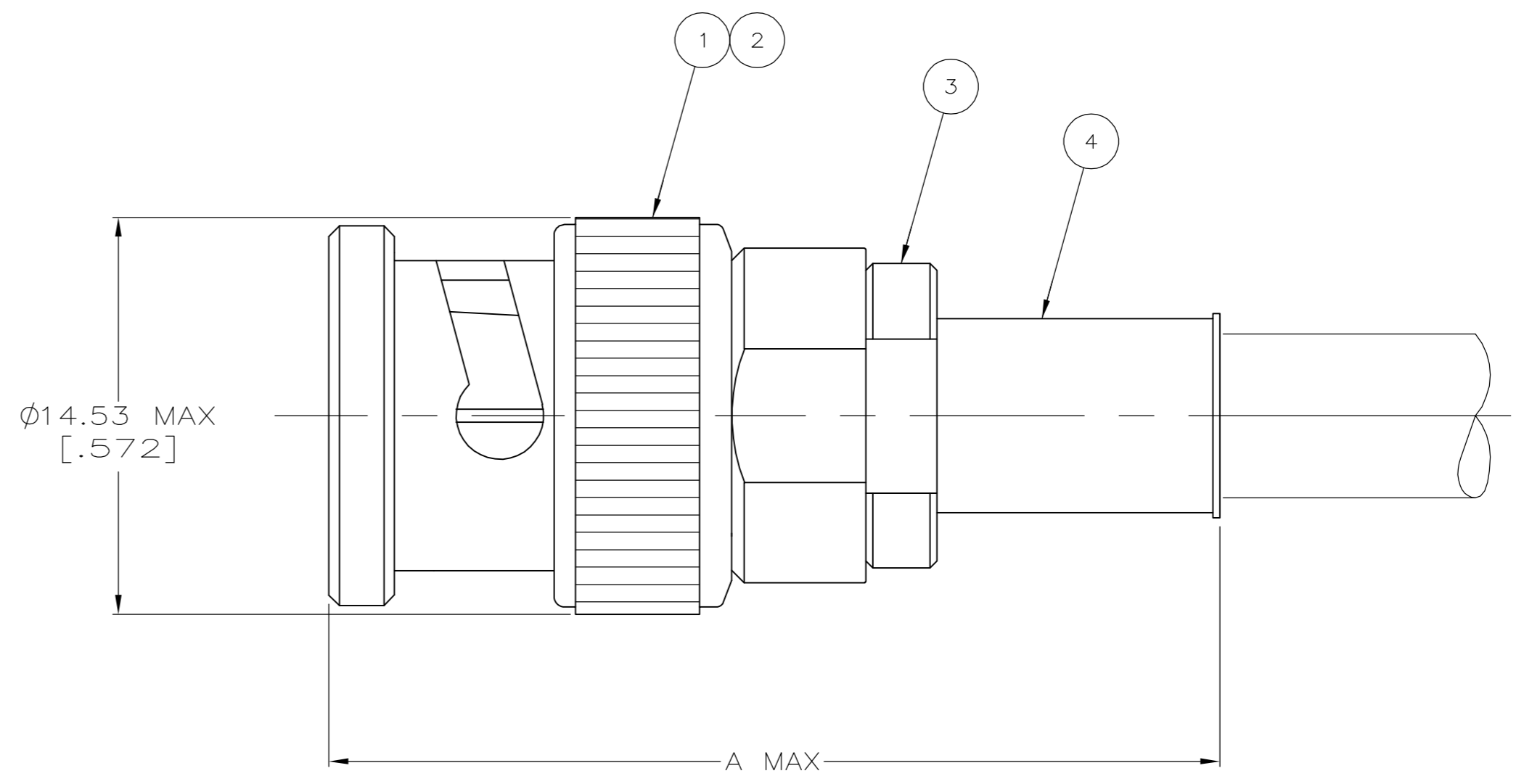

34.93 [1.375]	Ø	.416 OZ	9-329041-0	9-50780-6	2-329106-1	9-329327-1	2-5329083-1
A	CABLE	WEIGHT	4 FERRULE QTY=1	3 CRIMP END ASSEMBLY QTY=1	2 GASKET QTY=1	1 PLUG ASSEMBLY QTY=1	PART NUMBER

THIS DRAWING IS A CONTROLLED DOCUMENT.

DWN	A. FERNANDEZ	03FEB2005	 Tyco Electronics Corporation Harrisburg, PA 17105-3608			
CHK	J. HAVENER	03FEB2005				
APVD	J. LIPPERT	03FEB2005				
NAME	PLUG, SERIES BNC					
DIMENSIONS:	TOLERANCES UNLESS OTHERWISE SPECIFIED:	PRODUCT SPEC	SIZE	CAGE CODE	DRAWING NO	RESTRICTED TO
MM [INCHES]	0 PLC ± - 1 PLC ± - 2 PLC ± 0.41 [.016] 3 PLC ± - 4 PLC ± - ANGLES ± -	APPLICATION SPEC	A2	00779	C=5329083	-
MATERIAL	FINISH	WEIGHT	SCALE	SHEET	OF	REV
-	-	-	5:1	1	1	0

CUSTOMER DRAWING